

PGV Valves

*Rugged, Professional-Grade Valves Designed to
Handle the Full Range of Landscape Needs*

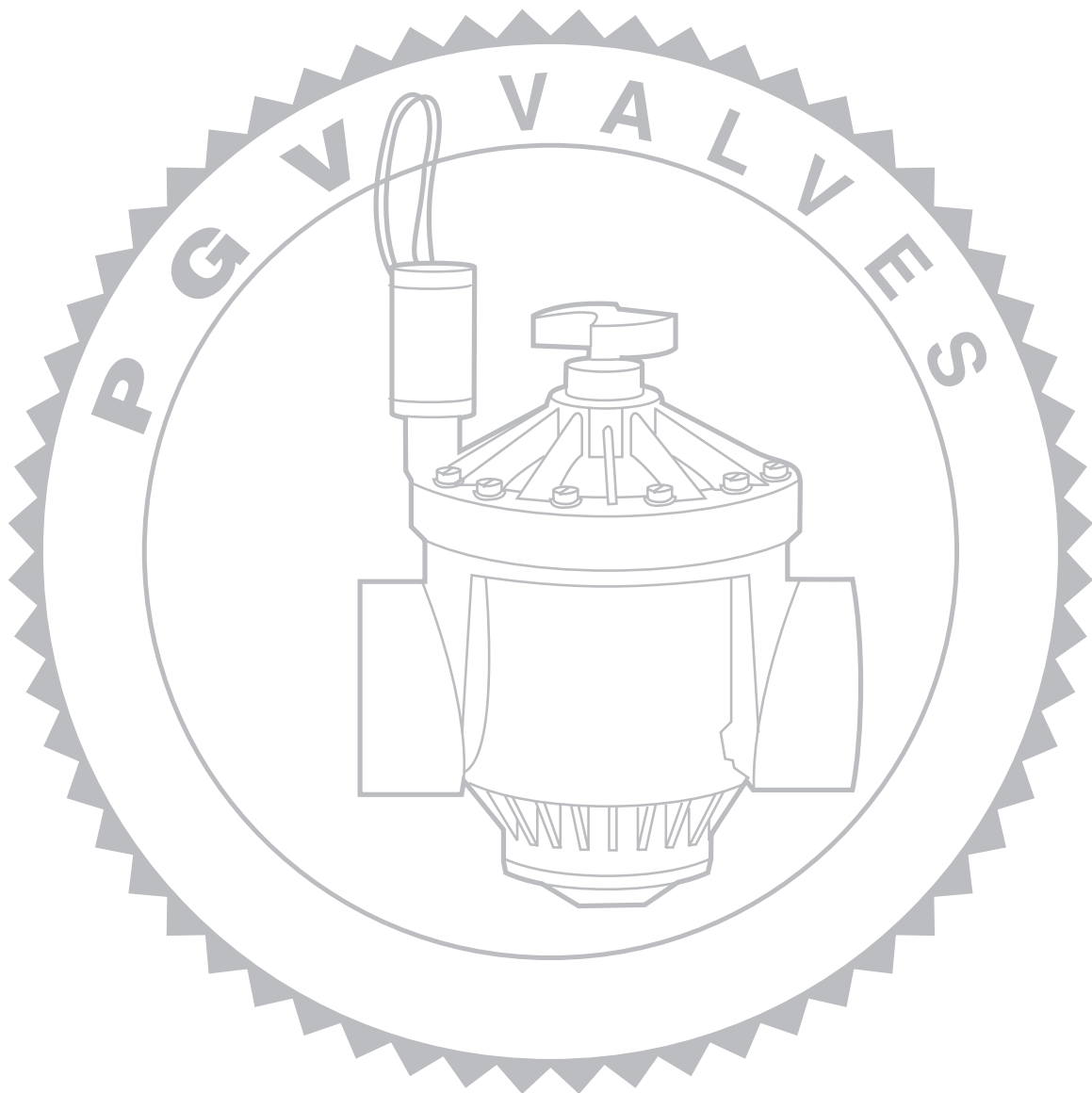

TABLE OF CONTENTS

Product Overview 1

Features and Benefits 2

Accu-Set™ Dial Control Pressure Regulation 6

Accu-Set™ Installation Instructions 6

Product Comparisons 7

Technical Information 8

Installation Details 9

Valve Operation 10

PGV Replacement Parts 11

PRODUCT OVERVIEW

The same HUNTER quality found in all of our remote control valves is also found in the PGV family. This **Professional Grade Valve** is a solid, heavy-duty performer designed to satisfy the requirements of the most demanding job sites.

Meets the Needs of All Residential/Commercial Projects

The versatility of the PGV valve is the answer to anyone who demands options. The valve is offered as an angle, globe or globe/angle combination in a full range of sizes, including 1" with or without flow control, 1½", and 2". Flow capability ranges from a low of 0.20 gpm (0.05 m³/hr, 0.76 l/m) all the way up to 120 gpm (27.2 m³/hr, 454.2 l/m).

Available as an option, the Hunter Accu-Set™ valve pressure regulator is an important tool for the professional installer. The Accu-Set™ is the product of choice for installation on PGV valves when the static supply pressure is just too high for sprinkler operation or when the irrigation main lines need to be at maximum pressures due to long pipe runs. Also, the Accu-Set™ is the ideal pressure regulator to use when different irrigation zones require different outlet pressures due to product specifications, such as sprays and rotors. Easy to install and easy to read, this dial-in pressure regulating module automatically adjusts as needed to provide an accurate and consistent working pressure in the zone piping.

Designed for Years of Life

Hunter developed the PGV valve with its multitude of features, because of a market need for a strong product with dependable performance.

The rugged, extremely tough body and bonnet contribute to a high pressure rating of 150 psi (10.3 bars, 1034 kPa). In addition, the valve features captive bonnet screws, diaphragm and a captive solenoid plunger. Plus, the heavy-duty Hunter solenoid, with its 5-year warranty, is sure to keep everything working for years and years.

Easy to Install, Easy to Maintain

Maintenance is an ongoing reality to any project and like all Hunter products, the easy-maintenance PGV was designed with the installation and service needs of the professional installer in mind. Offering a globe/angle configuration in one valve allows the installer to readily place the valve for easy access. The PGV's diaphragm, solenoid plunger, and bonnet screws are all captive parts, eliminating the chance of lost parts. Through-holes in the body allow dirt to fall through the screw holes instead of allowing it to pack at the bottom, where it can make it impossible to tighten the screw upon reassembly.

The bonnet screws used in the PGV line are unique to Hunter valves. These screws, specifically designed for use in plastic, thread quicker and truer into the valve body. They are compatible with a variety of tools: a hex nut driver, a Phillips screwdriver or slotted screwdriver for easy servicing. When installing irrigation systems, something as simple as a bonnet screw design is all that it takes to save time and money.

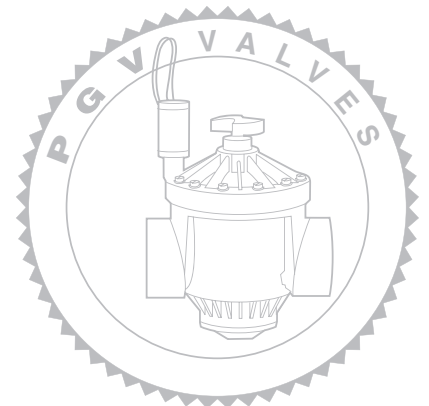

FEATURES AND BENEFITS

Globe or Angle Models...

Flexibility in design

Many times the irrigation main line is installed much deeper than the system's lateral lines. This may be due to local codes or for freeze protection. For these situations, Hunter offers 1½" and 2" valves with a globe/angle configuration in one valve. The globe configuration offers the best choice for those systems that have the main line at the same depth as the laterals. The angle configuration allows the installer to place the valve on top of a deep main line, which allows easy access to the valve for maintenance.

In addition, the PGV angle configuration boasts a lower pressure loss across the valve compared to a globe style valve, providing a big advantage on systems that may experience low operating pressures.

Body Options...

Maximum choices, minimum effort

Hunter is aware of the many different valve requirements that are prevalent in today's irrigation market. With that in mind, the PGV is designed as a very adaptable valve in the residential/commercial market. The PGV is available with a variety of inlet and outlet sizes and configurations: NPT, BSP, Male x Barb, Male x Male, and Slip.

The barb outlet valves have become an instant hit in the colder regions of the US, where polyethylene pipe is frequently used for laterals. Contractors report their installation times have decreased tremendously when this valve is used on their jobs. Eliminating the addition of an extra adapter or two to the manifold not only saves time and money, but also saves on the possibility of leaks.

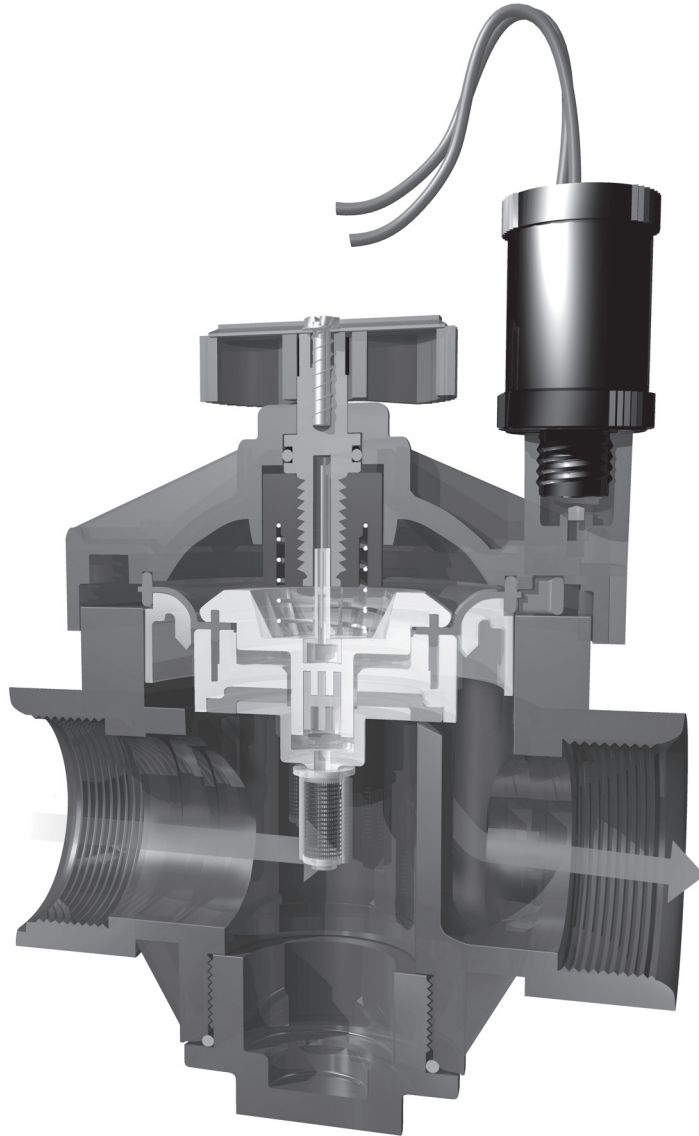

The many options available:

**1" GLOBE
with FLOW CONTROL**

fpt x fpt — NPT, BSP
mpt x mpt — NPT, BSP
mpt x barb — NPT, BSP
slip x slip



**1" GLOBE
without FLOW CONTROL**

fpt x fpt — NPT, BSP
mpt x mpt — NPT, BSP
mpt x barb — NPT, BSP
slip x slip



*Note: The 1" barb is sized for
USA poly markets only.*

**1" ANGLE
with FLOW CONTROL**

fpt x fpt — NPT

**1" ANGLE
without FLOW CONTROL**

fpt x fpt — NPT



**1½" GLOBE/ANGLE
with FLOW CONTROL**

fpt x fpt — NPT, BSP



**2" GLOBE/ANGLE
with FLOW CONTROL**

fpt x fpt — NPT, BSP

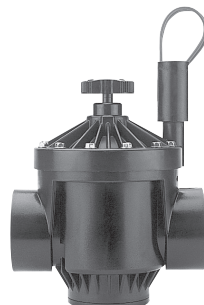

Barbed Connections...

Poly pipe connections made easy

An overwhelming request by Hunter valve users was to develop a valve with a barb outlet connection built into the valve for poly pipe users.

Hunter responded with four 1" models to choose from. The 1" globe with flow control in MNPT and MBSP threads

and the 1" globe without flow control in both MNPT and MBSP threads are now available.

With all of these models, the time-saving benefits have proven to be substantial for the installer, because they no longer need to thread adapters or nipples wrapped with Teflon tape into the valve to attach to poly pipe systems.



Flow Range...

Highly versatile valve for all flow requirements

The flow range of the PGV is exactly what installers are looking for in 1", 1½", and 2" valves. Systems requiring a flow rate as low as 0.20 gpm (12 gph), such as for low-volume irrigation, are easily accommodated with the 1" PGV. Also, irrigation systems running up to 120 gpm per zone, which can be found on large commercial sites, are well within the 2" valve's designed capabilities.

High-Grade Materials Used for a 150 psi Rating...

Made of durable materials to resist wear

If you are in the market for a valve that needs to take the pressure, the PGV is your choice. Featuring solid heavy-duty construction built with an ABS skirted bonnet, this valve takes up to a constant 150 psi without regard to hot summer temperatures. The superior design of the PGV helps eliminate any reduction in performance when temperatures go up: a common occurrence with 100% PVC constructed valves.

FEATURES AND BENEFITS *(continued)*

Heavy-Duty Solenoid...

Provides dependable operation and long life

The entire line of Hunter valves has something in common: the same heavy-duty five-year warranty solenoid. Hunter's "Totally Encapsulated" solenoid design features a completely closed bobbin core and glass reinforced nylon over-molded case. This rugged design provides increased protection to the solenoid coil from water intrusion – a primary cause of failures in solenoids. Installers will find that not having to stock two or three different solenoids for valves of the same manufacturer are a real plus. Another plus is the solenoid's captive plunger, which enables easy servicing of the solenoid but eliminates the chance for any lost internal parts.

It only takes 1½ turns to remove or replace the solenoid which makes twisted solenoid wires a non-issue (a tremendous benefit to installers or maintenance people who work with valves).

The Hunter solenoid is unique because it operates on a reverse flow principle. The center hole in the solenoid bowl is an inlet port, instead of an exhaust port. When installing long wire runs, this solenoid is very efficient, especially under high system pressures.

A big advantage to this reverse flow action is that it reduces potential large pressure spikes against the valve. Such spikes could cause damage not only to the valve, but to other components of the irrigation system as well. With the PGV, when a surge pressure spike hits the closed valve, the solenoid plunger will open slightly to allow the spike to travel downstream and dissipate through the zone piping, minimizing any damage that could occur. The solenoid plunger then closes immediately, preventing unscheduled system operation.

Captive Bonnet Screws, Diaphragm and Solenoid Plunger...

No lost parts during servicing

When servicing is required, the PGV is the valve that makes it easy. The screws, captive within the bonnet, are designed to be removed by a nut driver, Phillips, or slotted screwdriver. Another unique characteristic to the PGV line is the type of screw used. Specifically designed for use in plastic, the screw sports a large thread gain, allowing it to thread quicker and truer into the valve body.

In addition, all parts are captive within the solenoid (a great feature in a valve, assuring those parts will not be lost in the mud). The PGV also features screw through-holes in the valve body for trouble-free screw placement. If dirt gets into these holes it's no problem: as the screw is turned into the body, the dirt comes out the bottom. (It sounds simple, but other brands actually require removal of the valve to clean out the debris.)

Fully Supported Diaphragm...

Prevent stress failure in tough conditions

The PGV diaphragm is fully supported by an ingenious diaphragm support ring designed to prevent premature stress failure. The ring is also designed with small holes in it. These holes allow water to keep the diaphragm from sticking to the support ring after periods of non-use, such as before the landscaping is installed or winter shutdown.



Diaphragm support ring prevents stress failures.

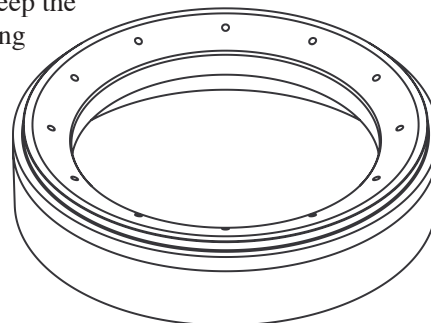

Diaphragm support ring prevents stress failures.

Debris Tolerant...

Designed to eliminate failure caused by debris

With the PGV valve installed in the irrigation system, callbacks for weeping valves are a thing of the past. The PGV is highly debris tolerant because of its “crowned” body seat and a revolutionary new polymer that is used in the diaphragm seat assembly.

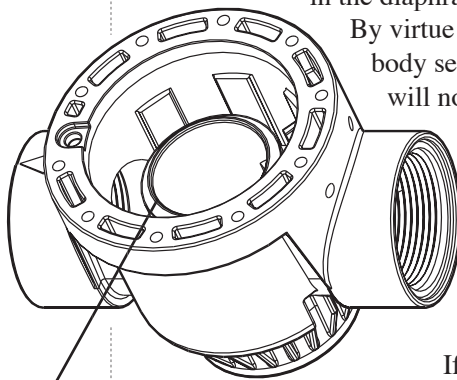

Crowned body seat

By virtue of the fact that the body seat is crowned it will not allow any contaminants to catch during valve closing, making it very difficult for debris to become trapped by the diaphragm.

If debris were to become imbedded in the diaphragm seat, the polymer material utilized in the diaphragm seat retains its original shape after the imbedded debris is flushed through the valve.

Adjustable Flow Control With Non-rising Handle...

Flow adjustment and servicing made easy

Flow management is a simple process when using the Hunter PGV with its non-rising flow control handle in the 1½" and 2" sizes. A non-rising handle means the valve can be placed

Non-rising flow control handle

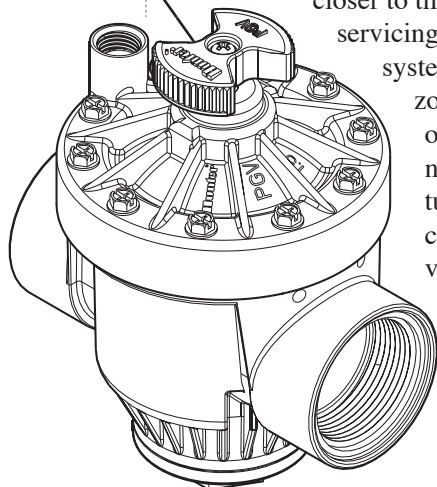

closer to the valve box lid for easier servicing. When fine tuning the system, adjust to the desired zone flow either by hand or using a valve key. If necessary, the easy-to-turn flow control handle completely shuts the valve off without the possibility of damage to the diaphragm, even under maximum pressure and flow conditions.

Optional Flow Control in 1" Sizes

Facilitates flow management as needed

The 1" PGV can be ordered with or without an optional flow control stem. With the flow control option, zone water pressure and flow can be managed right at the valve for optimum efficiency. A removable flow control handle, generously sized for easy gripping, makes flow adjustment a quick and easy process.

Heavy-Duty Bonnet...

Designed to provide maximum durability

Through repeated testing of valve designs, the PGV has incorporated in it a bonnet that goes beyond the typical plastic valve bonnet. The design features a skirt around the perimeter of the bonnet, which gives it incredible rigidity or “hoop strength.” An example of this would be the difference in rigidity between a Styrofoam cup with a lid attached and one without a lid attached. Without a lid, the cup is very malleable, but when a lid is attached the cup walls are strengthened tremendously.

Bonnet Air Relief...

Air release to minimize system stresses

The PGV is designed with a patent pending special air relief feature that facilitates the removal of any air bubble from the top underside of the bonnet. The removal of air facilitates the elimination of water hammer. When the flow control stem is pushed downward, any air trapped in the valve is released. The water pressure will then force the stem back up into place without leaking.

Internal Manual Bleed...

Completely dry manual operation

For fast manual operation, a quick ½ turn of the solenoid allows water to bleed off of the top of the diaphragm and, as a result, opens the valve. All the water goes through the valve, which means no more water continuously leaking into valve boxes.

FEATURES AND BENEFITS (continued)

Accu-Set™ Dial Control Pressure Regulation...

For use on 1½" and 2" valves

Exact pressure settings are a certainty every time with Hunter's Accu-Set™ pressure regulating module with its easy-to-read dial settings. This dial assures exact downstream pressure between 20 and 100 psi (1.4 to 7.0 bars, 138 to 689 kPa). There are no extra gauges to carry for pressure adjustments or inspection. (A schraeder valve is included on the unit for job specifications requiring checking and setting using a gauge only.)

The Accu-Set dial-in module provides an accurate working (or dynamic) pressure to the zone. The module constantly adjusts as needed to provide a consistent outlet pressure regardless of inlet pressure variations.

The Accu-Set pressure regulator is an important tool a professional installer will use when the irrigation main lines need to be at maximum pressures due to long pipe runs or when static supply pressures are too high for sprinkler operation. Also, the Accu-Set is the product of choice when different zones require different outlet pressures due to product specifications, such as large rotor sprinklers zoned off the same main line as sprayheads.

The benefit of the Accu-Set is that the irrigation system does not need to be pressurized to adjust it, resulting in a very fast installation. With this unique pressure regulating module, just set the easy-to-read dial to the desired pressure, with or without the system operating. The pressure dialed in is the pressure delivered to the zone.

The optional Accu-Set pressure regulating module is easy to retrofit on 1½" and 2" field installed PGV valves. On systems determined to have high-pressure problems after installation, the amount of time saved in labor, along with reduced costs, is considerable. That's because the Accu-Set is installed without a hassle, without cutting pipe and without replacing valves.

Accu-Set Installation Instructions

1. Remove the solenoid from the Hunter PGV irrigation valve. (The 1" valve with flow control is not designed for use with the Accu-Set.)

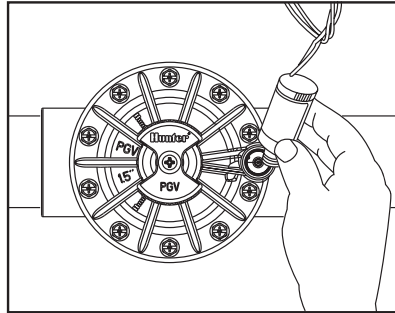

2. Thread the Accu-Set into the solenoid area of the PGV.

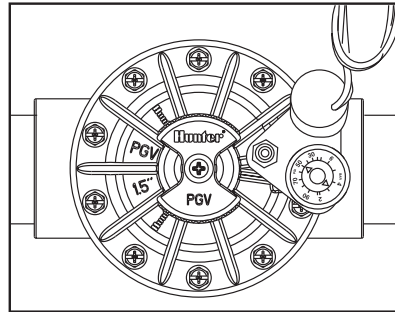

3. Thread the solenoid into the Accu-Set.

Accu-Set Pressure Regulator Adjustment

1. Turn the clear dial on the top of the Accu-Set until the arrow underneath the clear dial is pointing to the desired downstream pressure.
2. The white colored scale is for PSI, the yellow colored scale is for BAR.

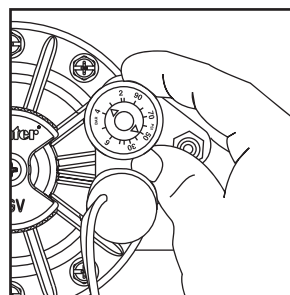

PRODUCT COMPARISONS

Features	Hunter PGV	Rainbird PGA	Irritrol 200B	Toro 252	Nelson 7900	Weathermatic 21000
150 PSI Rated Operating Pressure	✓	✓	✓	✓	✓	✓
Models to Accommodate Globe/Angle Configuration	✓	✓	✓	✓	✓	
Flow Control with Non-Rising Handle	✓	✓				✓
Internal Manual Bleed	✓	✓	✓		✓	✓
Bonnet Air Relief	✓		✓	✓	✓	
Captive Diaphragm	✓				1" model	
Captive Bonnet Screws	✓		✓		1" model	
Triple Tool Stainless Steel Bonnet Screws	✓		✓		1" model	
Easy Bonnet Removal (4 Screws on 1" Valve)	✓				✓	
Less Than 1½ Turns to Remove Solenoid	✓					
Reverse-Flow Solenoid Design to Reduce Line Surges	✓					
Interchangeable Solenoid with All Hunter Plastic Valves	✓		✓		✓	
Female Inlet/Outlet – NPT / BSP Option	✓	✓	✓	✓	✓	✓
Male Inlet/Outlet – MPT / Barb Option	✓					
1" Valve Inlet/Outlet – Solvent-Weld Slip Option	✓					
Vent Holes in Diaphragm Support	✓					
Dial to Setting Pressure Regulator Option without extraneous tubing	✓		✓			
Less Than 2.5 PSI Loss at 25 GPM in 1" Valve	✓					
Less Than 3.1 PSI Loss at 100 GPM in 2" Valve	✓			✓		
Optional Conduit Cover	✓	✓	✓		✓	

SPECIFICATION GUIDE

EXAMPLE: **PGV - 100G - S - AS**

MODEL PGV	FEATURES	OPTIONS FACTORY INSTALLED	OPTIONS USER INSTALLED
	100G = 1" Globe Valve, no Flow Control 101G = 1" Globe Valve, with Flow Control 100A = 1" Angle Valve, no Flow Control 101A = 1" Angle Valve, with Flow Control 100MB = 1" Globe Valve, no Flow Control, Male Thread x Barb 100MM = 1" Globe Valve, no Flow Control, Male x Male 101MM = 1" Globe Valve, with Flow Control, Male x Male 151 = 1½" Globe/Angle Valve, with Flow Control 201 = 2" Globe/Angle Valve, with Flow Control	S = Slip x Slip (1" Models Only) B = BSP Threads DC = DC Latching Solenoid	AS = Accu-Set™ Pressure Regulator (1½" and 2" Models Only) R = Reclaimed Water Identification Handle or Tag CC = Conduit Cover

TECHNICAL INFORMATION

Models

- PGV-100G – 1" plastic globe valve
- PGV-101G – 1" plastic globe valve with flow control
- PGV-100A – 1" plastic angle valve
- PGV-101A – 1" plastic angle valve with flow control
- PGV-100MM – 1" plastic globe valve, male x male threads
- PGV-101MM – 1" plastic globe valve with flow control, male x male threads
- PGV-100MB – 1" plastic globe valve, male thread x barb
- PGV-101MB – 1" plastic globe valve with flow control, male thread x barb
- PGV-151 – 1 1/2" plastic globe/angle valve with flow control
- PGV-201 – 2" plastic globe/angle valve with flow control

Dimensions

- 1" Globe – 5" H (13 cm) x 4 1/2" L (11 cm) x 2 1/2" W (6 cm)
- 1" Angle – 5 1/2" H (14 cm) x 3 1/2" L (9 cm) x 2 3/4" W (7 cm)
- 1 1/2" Globe/Angle – 7 1/2" H (19.1 cm) x 5 3/4" L (14.6 cm) x 4 1/2" W (10.8 cm)
- 2" Globe/Angle – 8" H (20.3 cm) x 6 3/4" L (17.1 cm) x 5 1/4" W (13.3 cm)

Operating Specifications

- Flow: 0.20 to 120 gpm (0.05 to 27.2 m³/hr; 0.76 to 454.2 l/min)
- Pressure: 20 to 150 psi (1.4 to 10.3 bars; 138 to 1034 kPa)
- Heavy-duty solenoid: 24VAC, 370mA inrush current, 190mA holding current, 60 cycles
- 475mA inrush current, 230mA holding current, 50 cycles

OPTIONS Available

- Accu-Set™ pressure regulator
- Reclaimed water identification handle
- DC latching solenoid
- Conduit cover

PGV Pressure Loss in PSI

GPM	1" Globe	1" Angle	1 1/2" Globe	1 1/2" Angle	2" Globe	2" Angle
1	1.1	1.0				
5	1.9	1.0				
10	1.9	1.0				
15	1.6	1.0				
20	3.3	2.0	3.0	3.0	1.0	1.0
30	6.1	3.0	3.0	3.0	1.0	2.0
40			3.0	3.0	2.0	2.0
50			4.0	3.5	1.0	1.0
60			5.0	4.0	2.0	2.0
80			5.5	4.5	3.0	2.0
100					5.0	3.0
120					6.0	5.0

PGV Pressure Loss in Bars

m ³ /hr	1" Globe	1" Angle	1 1/2" Globe	1 1/2" Angle	2" Globe	2" Angle
0.23	0.08	0.07				
1.14	0.13	0.07				
2.27	0.13	0.07				
3.41	0.11	0.07				
4.54	0.23	0.14	0.21	0.21	0.07	
6.81	0.42	0.21	0.21	0.21	0.07	
9.08			0.21	0.21	0.14	
11.36			0.28	0.24	0.07	
13.63			0.34	0.28	0.14	
18.17			0.38	0.31	0.14	
22.71					0.21	
27.25					0.34	

SRV Pressure Loss in kPa

l/min	1" Globe	1" Angle
4	7.58	6.89
19	13.10	6.89
38	13.10	6.89
52	11.03	6.89
76	22.75	13.79
114	42.06	20.68

INSTALLATION DETAILS

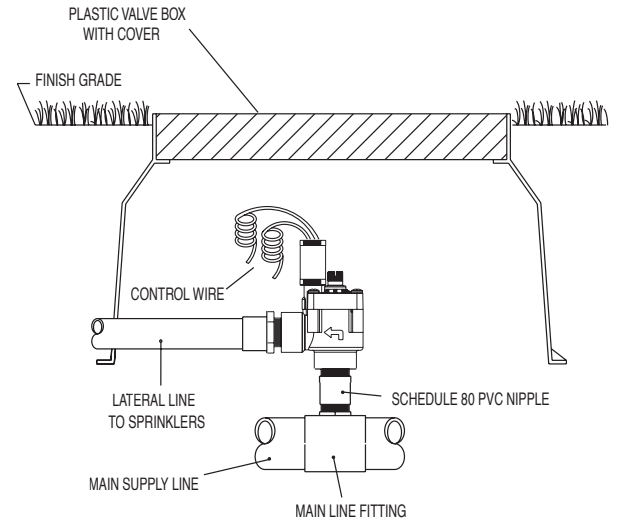
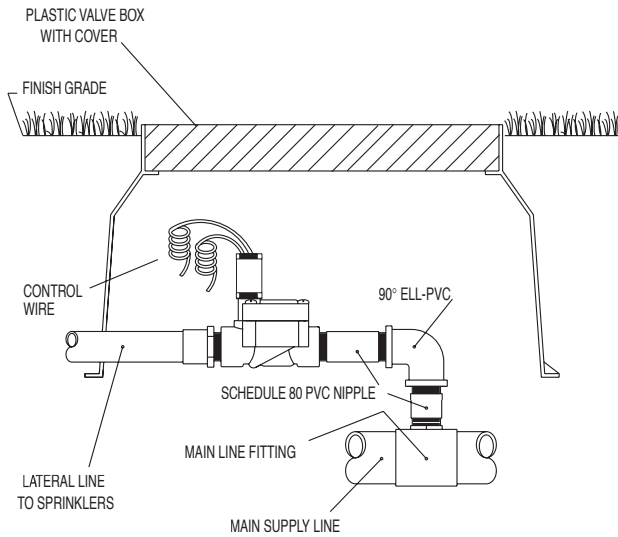

Hunter® 1" PGV-GLOBE

Hunter® 1" PGV-ANGLE

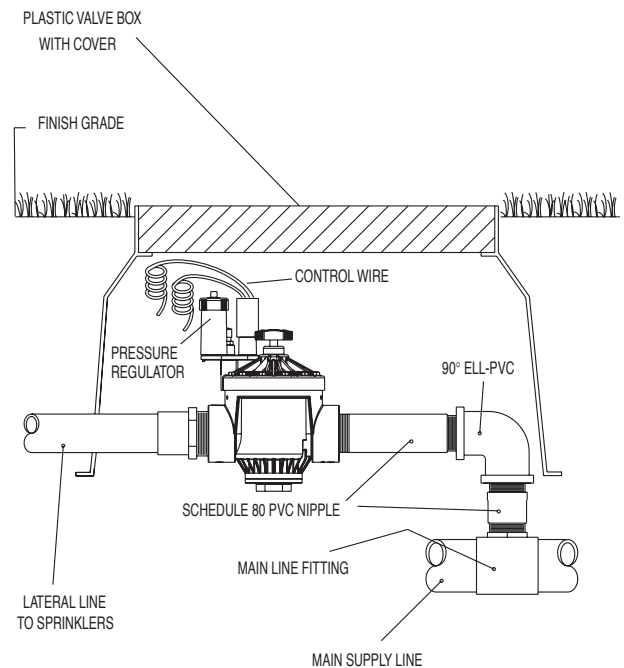
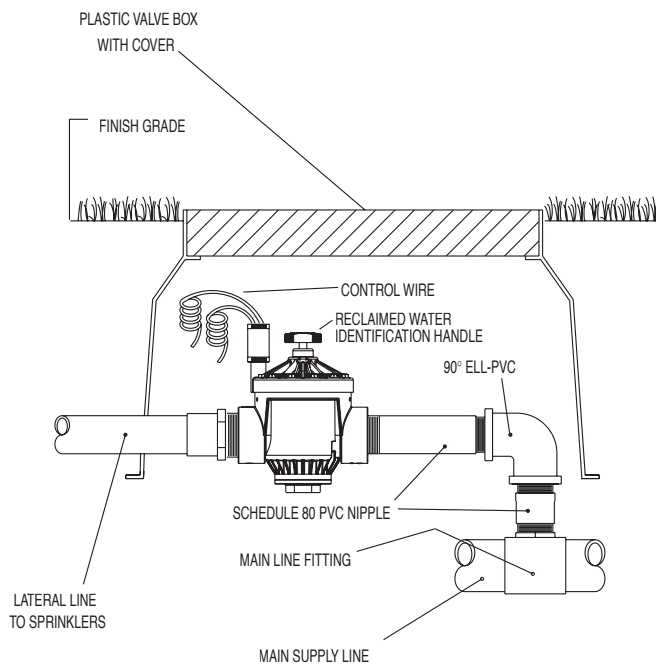

Hunter® 2" PGV-NP

Hunter® 2" PGVW/PR

VALVE OPERATION

Basic Principles of Valve Operation

Water enters the valve from the system main line and exerts a force against the center of the valve's diaphragm. A small orifice in the diaphragm allows the water to flow through to the upper chamber between the diaphragm and the bonnet. The water continues to travel on through a port in the bonnet to the solenoid area. The solenoid has a light spring loaded metal piston that, when the valve is closed, covers the inlet port hole. The surface area that the water comes in contact with on top of the diaphragm is greater than the surface area on the bottom of the diaphragm, so the valve stays closed until the water in the upper chamber is released. (pressure x area = force)

Electrically Opening a Valve

When the solenoid coil is electrically charged, the current creates an electromagnetic field and pulls the piston off of the port hole seat allowing water to flow into the solenoid chamber, out of the solenoid exhaust port, and into the downstream pipe. The solenoid ports are larger than the orifice in the diaphragm, so the water flows out of the upper diaphragm/bonnet chamber faster than it is allowed to enter. The pressure on the top of the diaphragm is released through these ports, and the force from the mainline side pushes against the diaphragm and causes the valve to open.

Manually Opening a Valve

The same principle is at work when a valve is manually opened using the manual bleed. The pressure on the top of the diaphragm is released through the use of an internal or external bleed. The internal bleed on the PGV mechanically lifts the solenoid piston off of the upper chamber exhaust port allowing the water to be released into the downstream pipe. Some valves have an external bleed which allows water to exit the upper diaphragm chamber into the valve box.

Closing a Valve

When the controller turns off the low voltage current flow, the solenoid piston spring pushes the piston back over the inlet port, and stops the flow of water from going through the solenoid chamber and exhaust port. The upper diaphragm/bonnet chamber begins to fill, and soon reaches an equilibrium point when the psi (pounds per square inch) is the same on both sides of the diaphragm. The diaphragm spring continues to gently push on the diaphragm, closing the valve further. The combination of the spring exerting pressure on the diaphragm and the water building up in the upper chamber bring the valve to a closed position.

PGV-100G/101G: PLASTIC VALVES

Item	Description	Catalog No.	
①	Solenoid Assembly	AC Solenoid	434100
	(Includes Parts 2 & 3)	DC Solenoid	458200
②	O-Ring	262600	
③	Solenoid Seal	364400	
④	Bonnet Screw	427300	
⑤	Bonnet without Flow Control	458000	
⑥	Bonnet with Flow Control	435005	
⑦	Diaphragm Spring	266000	
⑧	Diaphragm Assembly	332100	
⑨	Diaphragm Support Ring	331300	
⑩	Body	Female, NPT Thread	457700
		Female, BSP Thread	457705
		Female, Slip x Slip	457710
		Male x Male, NPT	433400
		Male x Male, BSP	433405
		Male x Barb, NPT	460700
		Male x Barb, BSP	460705
⑪	Flow Control Handle	Black	269200
		Purple	269205

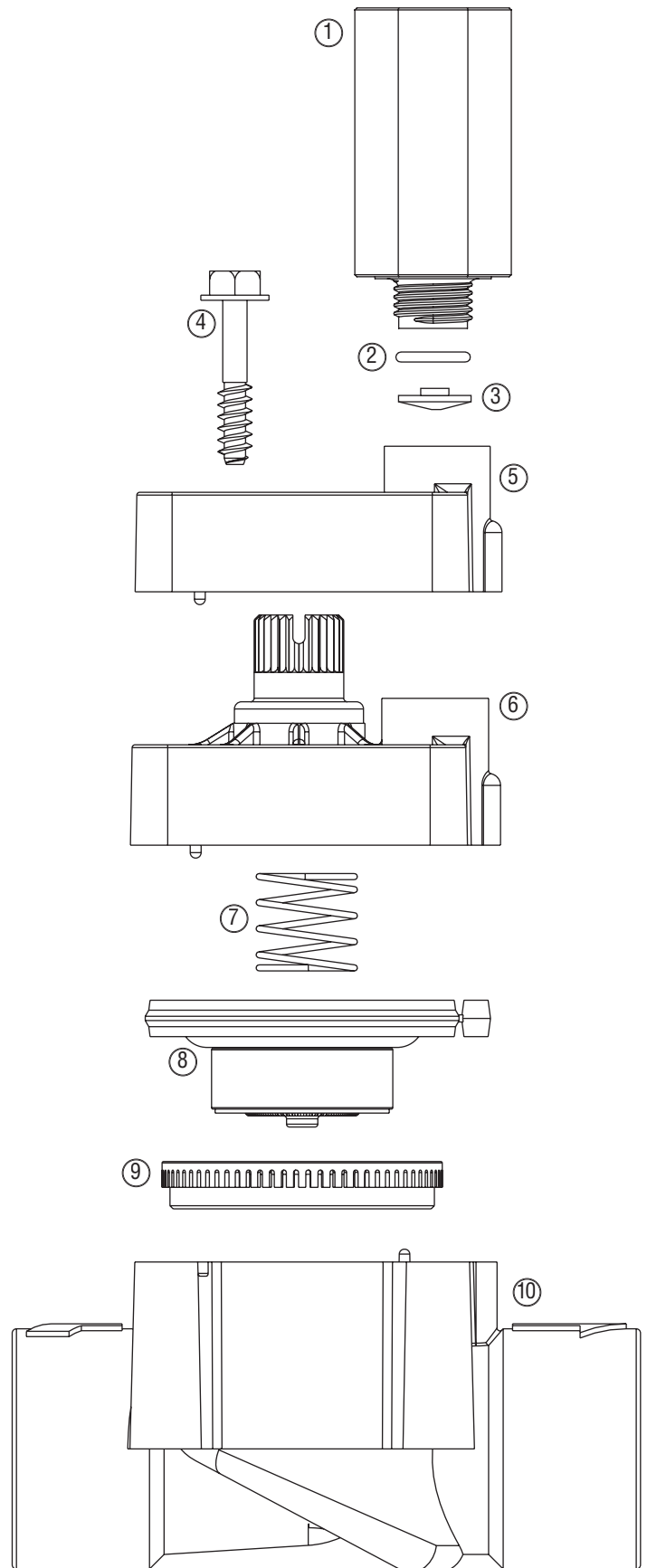

PGV-100A/101A: PLASTIC VALVES

Item	Description		Catalog No.
①	Solenoid Assembly (Includes Parts 2 & 3)	AC Solenoid	434100
		DC Solenoid	458200
②	O-Ring		262600
③	Solenoid Seal		364400
④	Bonnet Screw		427300
⑤	Bonnet with Flow Control		379405
⑥	Bonnet without Flow Control		435005
⑦	Diaphragm Spring		266000
⑧	Diaphragm Assembly		332100
⑨	Diaphragm Support Ring		331300
⑩	Body		407000
⑪	Flow Control Handle	Black	269200
		Purple	269205

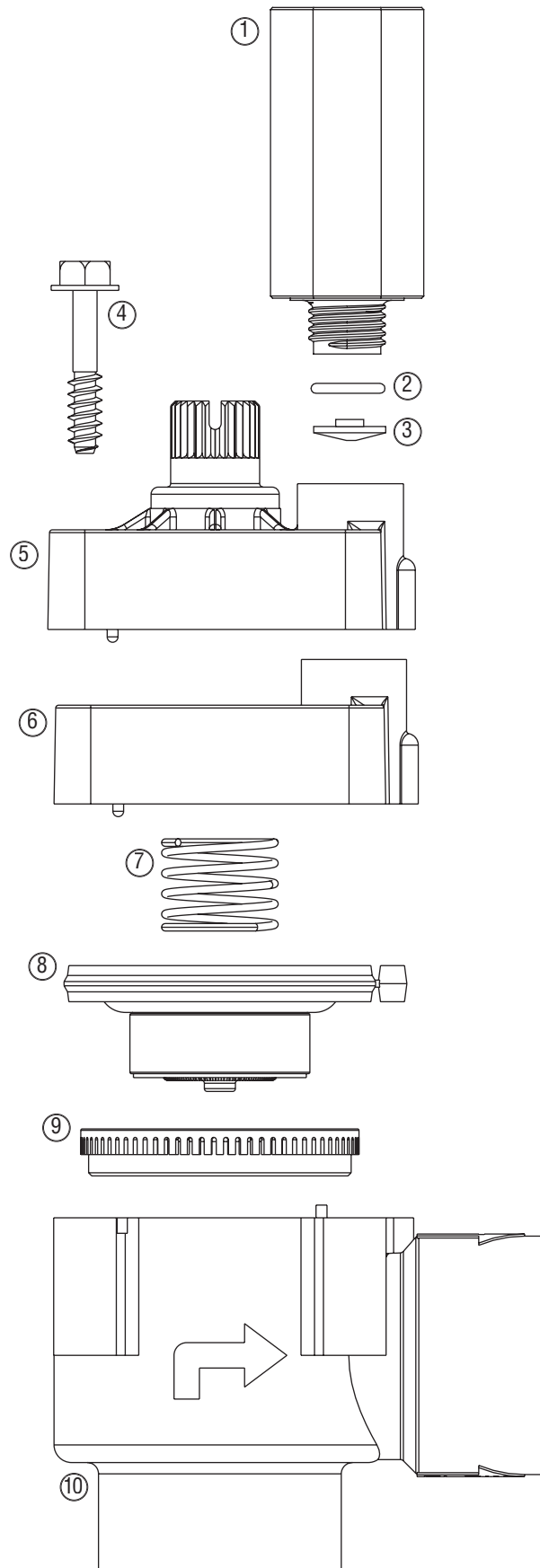

PGV-151G, 201G: PLASTIC VALVES

Item	Description		Catalog No.
①	Solenoid Assembly (Includes Parts 2 & 3)	AC Solenoid	434100
		DC Solenoid	458200
②	O-Ring		262600
③	Solenoid Seal		364400
④	Flow Control Handle Screw		334000
⑤	Flow Control Handle	Black	412700
		Purple	412705
⑥	Bonnet Screw		472800
⑦	Bonnet	1½"	414000
		2"	415500
⑧	Flow Control Stem (Includes O-Ring, Stem, Nut and Rod)	1½"	421500
		2"	414600
⑨	Spring	1½"	412300
		2"	414200
⑩	Diaphragm Assembly	1½"	414100
		2"	415600
⑪	Diaphragm Support	1½"	413100
		2"	414800
⑫	Body	1½" NPT	433200
		1½" BSP	433205
		2" NPT	433300
		2" BSP	433305
⑬	Body Plug without O-Ring	1½" NPT	419200
		1½" BSP	419205
		2" NPT	419300
		2" BSP	419305
⑭	Plug O-Ring	1½"	413900
		2"	415400

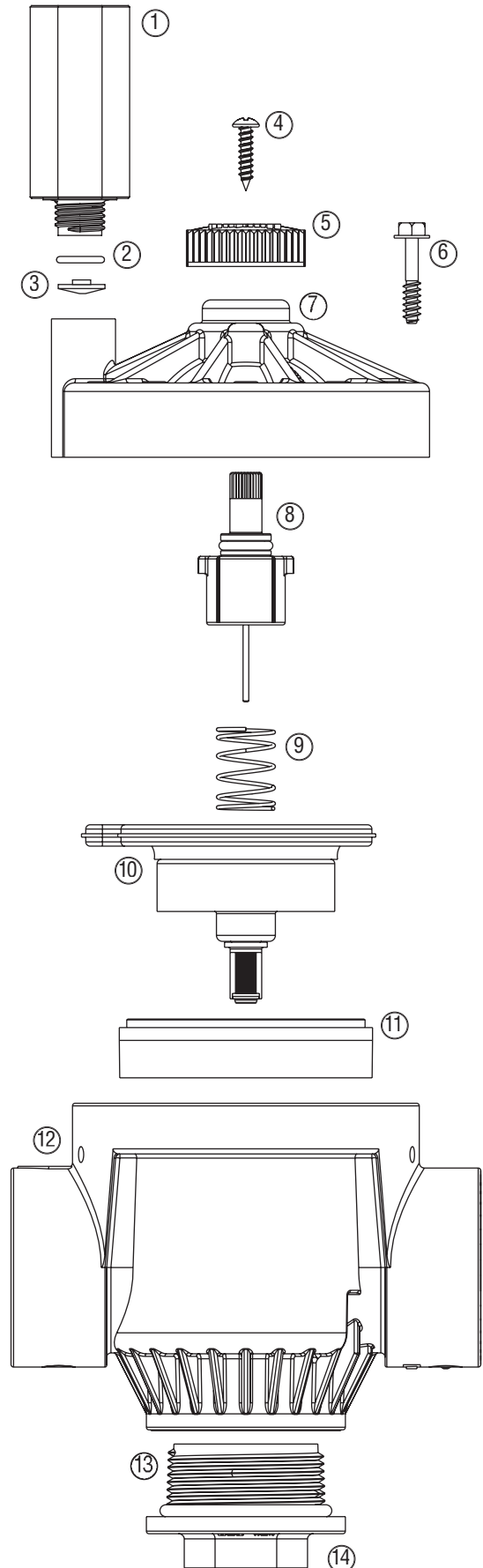

ACCU-SET™

Item	Description	Catalog No.
①	Adjustment Knob	368500
②	O-Ring	262600
③	Inlet Seal	368200

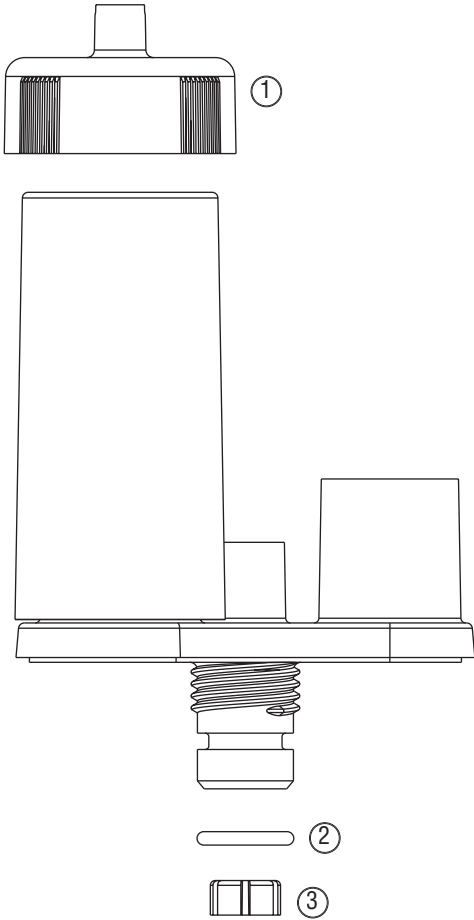



Hunter®

Hunter Industries Incorporated • The Irrigation Innovators

1940 Diamond Street • San Marcos, California 92069 • TEL: (1) 760-744-5240 • FAX: (1) 760-744-7461
www.HunterIndustries.com

© 2003 Hunter Industries Incorporated

P/N 700651 LIT-294 1/03